



# **VOGUE**

**ABOVE GROUND SWIMMING POOL**

**LINER INSTALLATION**

**PLUMBING GUIDE**

**OPERATING GUIDE**

# LINER INSTALLATION TIPS

The liner installation is a straight forward procedure as long as you follow the instruction guide lines carefully depicted in the Vogue Installation manual.

All Vogue liners supplied in the UK are 'hung liners'. The PVC all patterned liner that you have received with your pool kit is manufactured in one piece. Welded to the top of the liner is a 'white beading'. The beading is designed to hung onto the pool wall and held in position by the 'top-rails'.

Liners are manufactured slightly undersize to allow for the PVC material to stretch into position to ensure a 'crease free' fit. With this in mind, you may find that in that you are unable to place all of the liner bead (especially in cooler temperatures i.e. 60 - 65 deg.F) onto the pool wall.

## DO NOT ATTEMPT TO FIT A LINER IF TEMPERATURE IS BELOW 60 deg.F

### Before attempting to fit a liner.

- Have a minimum of two people, ideally three to help you instal the liner.
- Check the label description on the box, to make sure that you have been supplied the correct liner.
- Make sure that all footwear is removed prior to entering the pool floor area.
- Thoroughly clean, sweep & Hoover any visible debris, small stones etc.

### What to do if the liner does not fit.

If the liner seems to be too small then the liner material may be too cold! Try the following:-

Place as much of the liner (beading) onto the top of the pool wall as possible, making sure that the liner's vertical seam weld is vertical and perpendicular to the pool wall and floor (as described in the installation manual).

Using a piece of 2" 'liner-lock clip' (available from your dealer) place onto liner bead above the wall seam - **page 8** (dia.1b). The liner-lock clip will help lock the liner into position. Using a 'hair dryer' (dia.2b) heat approximately 24" of the beading and the liner material (this helps the beading and liner to become more pliable and easier to stretch). Ideally using two pairs of hands stretch the top of the beading as much as possible. Without letting go of the material apply another liner-lock clip. Repeat this procedure half way round the perimeter of the pool. Go back to the wall seam and stretch the remaining beading onto the pool wall. This method is applicable to oval and round pools.

You will find that stretching the liner bead in small intervals will enable you to place all of the liner bead onto the top of the pool wall!

Note. Once all of the liner has been installed, slight bulging will occur around top perimeter of the pool wall, this normal. A liner has a stretch factor of 170%!

### I have tried the above and the liner still does not fit. What do I do?

REPEAT the above procedure. The more you stretch the beading, the closer you will get to installing of the liner bead.

In the event that you are unable to fit the liner, use a cloth measuring tape and measure the perimeter of the white beading. Call your pool dealer with this measurement. Please also have the four digit number printed on the box (not the label) that the liner was packed in. Your pool dealer will advise you what to do next.

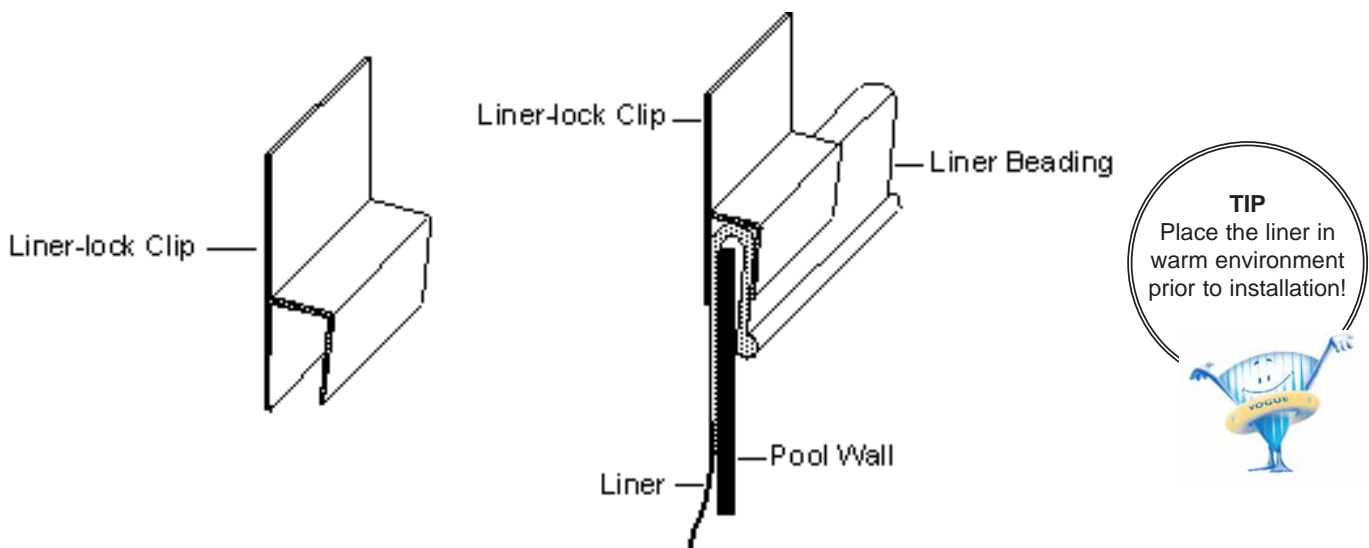

Liner requires stretching

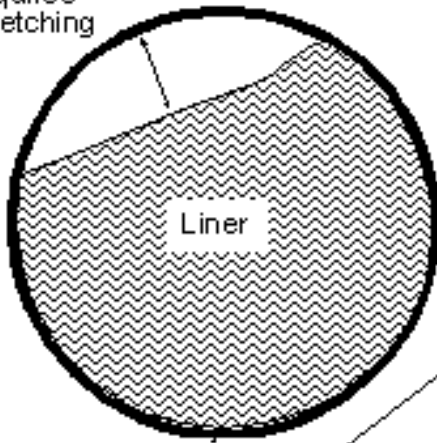

dia. 1b

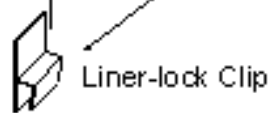

Place a liner-lock clip onto beading to hold liner in position.

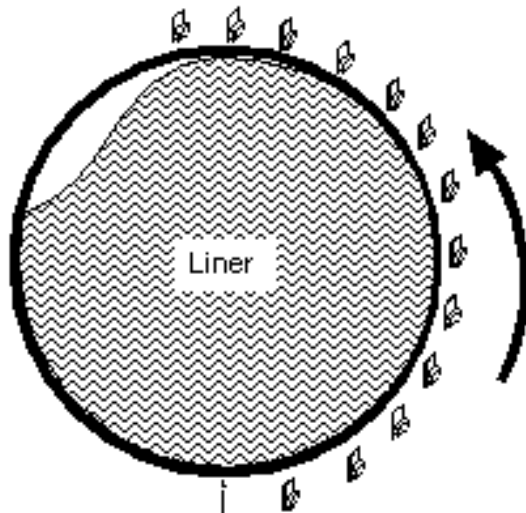
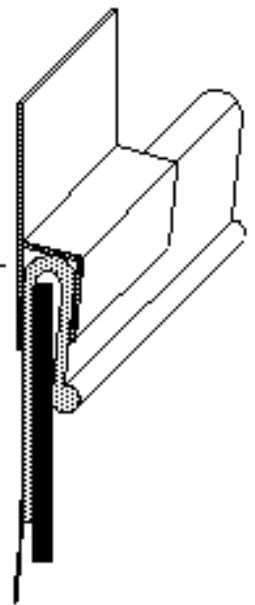

dia. 2b

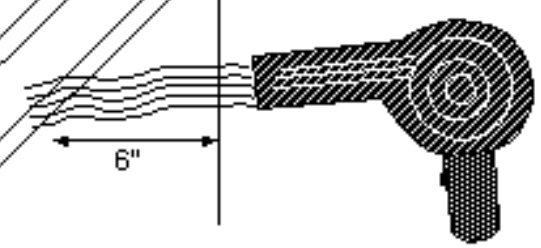
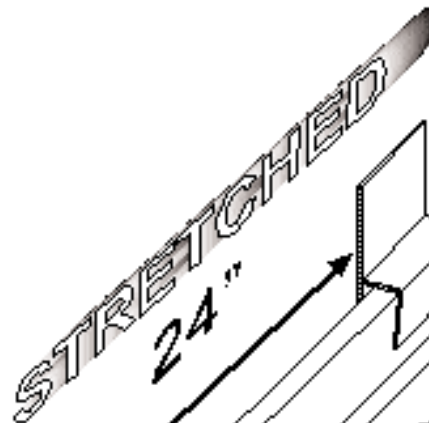
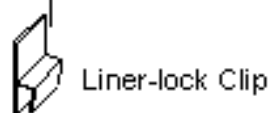

Hair dryer

Gently heat liner beading with a hair dryer and stretch approximately every 2ft and apply liner-lock clip.

Continue to stretch at 2ft intervals in the same direction until one half of the liner beading is secure.

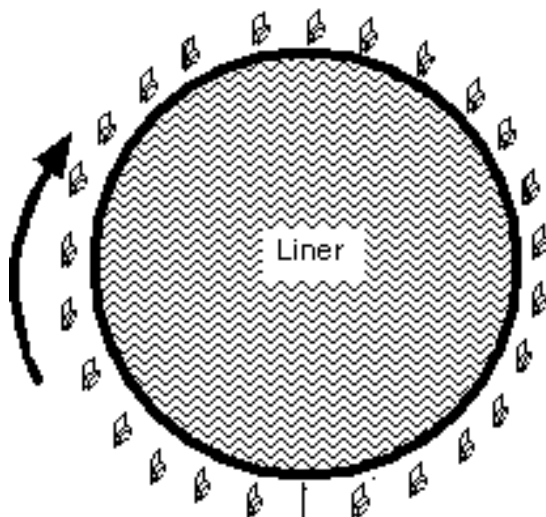

dia. 3b

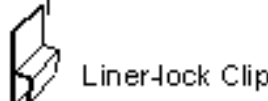

Once all of the liner has been installed you may notice that the pool wal liner bulges out. This is normal.

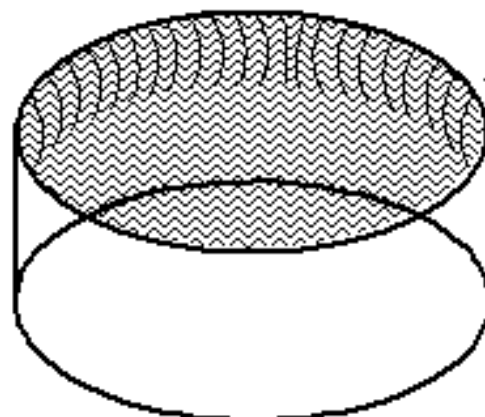

Bulging



# FLEXIBLE PLUMBING LAYOUT FOR ABOVE GROUND POOL

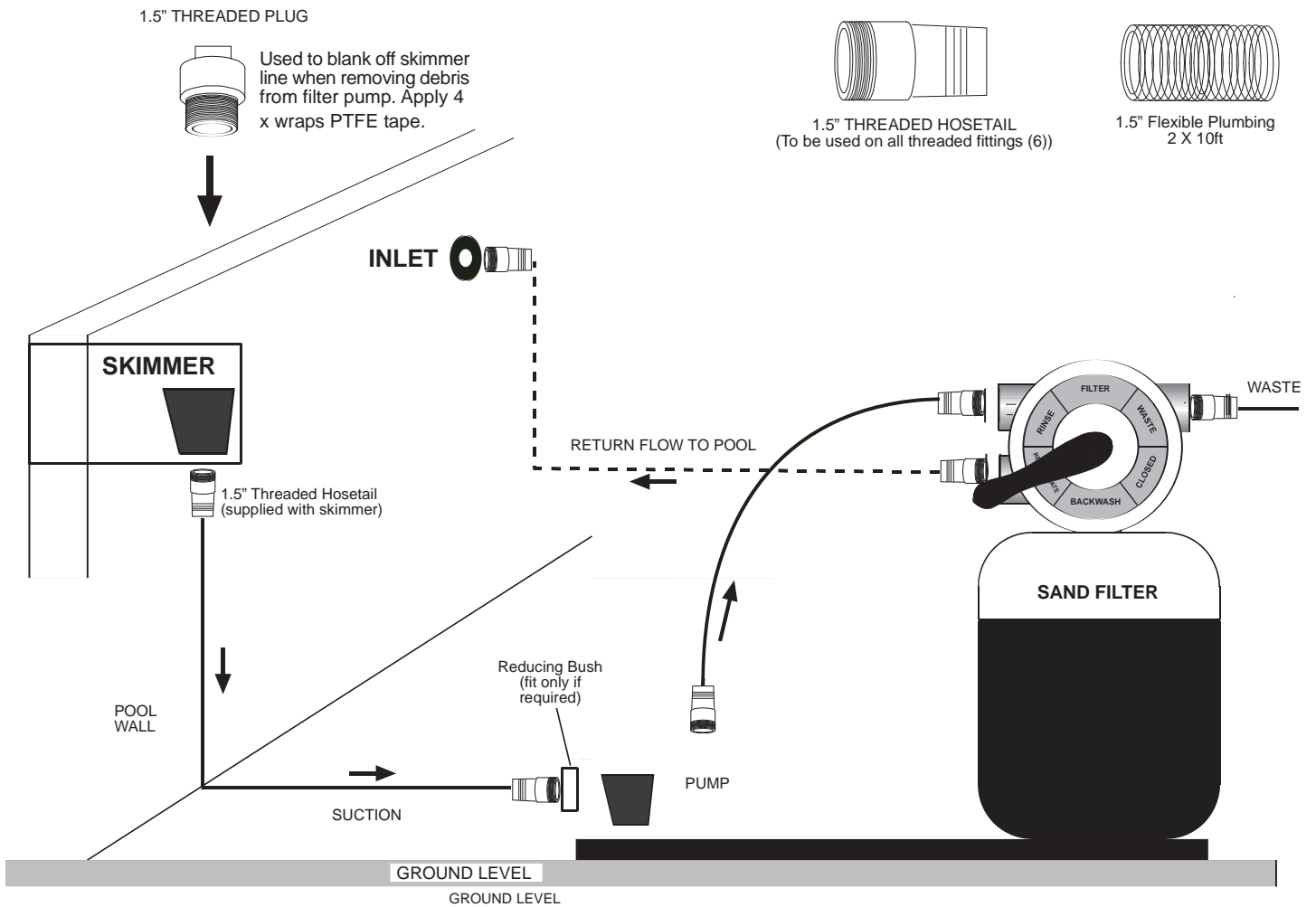

Prior to installing the filter and pump, please study the plumbing layout plan as shown above. Included in the pool kit is small amount of plumbing fittings and flexible pipework to enable you to site the filtration unit 2.5 metres away from the pool. However, plumbing configurations may vary in accordance with site conditions, ancillary equipment etc. therefore, extra plumbing may be purchased from your dealer.

All threaded fittings must have P.T.F.E (supplied) applied to them. Apply 15 -20 wraps of P.T.F.E onto a threaded fitting in a clockwise direction. As an extra precaution, it is a **good idea to apply a thin film of Silicone Sealant** prior to screwing the fitting into a threaded socket.

**All flexible pipe work must be secured using a 1.5" Jubilee Clip (supplied). Please see diagram below.**

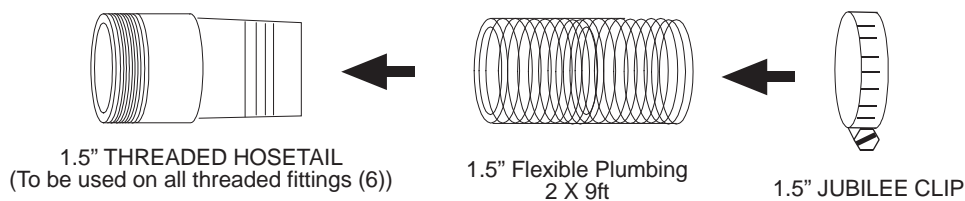

# POOL MAINTENANCE & OPERATING GUIDE

## STEP BY STEP THROUGH THE EQUIPMENT

**Surface Skimmer-** This will be found at the top side of the pool wall just under the top rail, the skimmer draws water and surface debris off the pool over a floating weir; debris is caught in the skimmer basket with the water being filtered. The skimmer basket will need to be checked and cleaned of debris on a regular basis. With the pump switched off; remove the skimmer lid and lift out the basket.

The water level must be maintained at least half way up the skimmer opening. Be aware that when the pool is in good use and heated evaporation can account for water loss of between 2" to 3" per week, even with the summer 'bubble' cover in place when the pool is not in use!

**Return Inlet-** Found in the wall about 12" underwater. This returns filtered water back to the pool.

**Circulation Pump-** A self-priming continuous rated pump with a pre-filter strainer pot draws the pool water from the skimmer and delivers it to the filter. The strainer pot basket will need cleaning on a regular basis. To carry this out, ensure the pump is switched off, close the suction valve in front of the pump and turn the multiport valve to 'closed', remove the pump lid, usually held on with two thumb knobs or a clamp band. Remove the basket and clean out, replace basket, top strainer pot up with water if required, replace lid ensuring that lid 'O' ring is in place and tighten, open valve and return multiport valve handle to 'filter' and switch pump on.

A pump is 'primed' when the strainer pot is full of water. If the water level in the pool drops below the skimmer opening or you take an attached vacuum head out of the water you will lose prime.

To 'prime' the pump. Ensure the pump is switched off, close the suction valve in front of the pump and turn the multiport valve to 'closed', remove the pump lid, fill strainer pot up with water, replace lid ensuring that lid 'O' ring is in place and tighten, open valve and return multiport valve handle to 'filter' and switch the pump on. The pump should prime within a few minutes, if not- repeat the above process, if this still fails call your pool supplier.

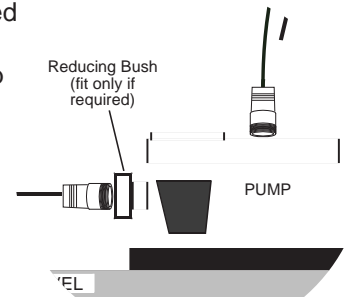
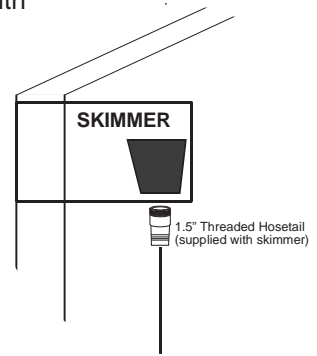

**Filter & 6-Way Multiport Valve-** The filter (silica sand unit) is placed by the side of the circulation pump. The multiport valve will be found on top of the filter, easily identified by a black selector valve 'handle'.



The sand filter takes soiled water from the pump and under pressure enters the top of the filter, this is then forced down through the sand, the sand traps debris and fine particles within it, allowing clean filtered water out of the bottom of the filter back to the pool - **see dia.1 below.**

The pressure gauge found on the multiport valve records the back pressure on the sand thus, as the sand becomes dirty the pressure will increase. When the pressure gauge has increased by approximately 20-30% a backwash cycle is required **see dia. 2 below.**

**REGARDLESS WHETHER YOUR FILTER IS DIRTY OR CLEAN IT IS IMPERATIVE THAT YOU BACKWASH AT LEAST ONCE A WEEK TO REMOVE CHEMICAL RESIDUE.**

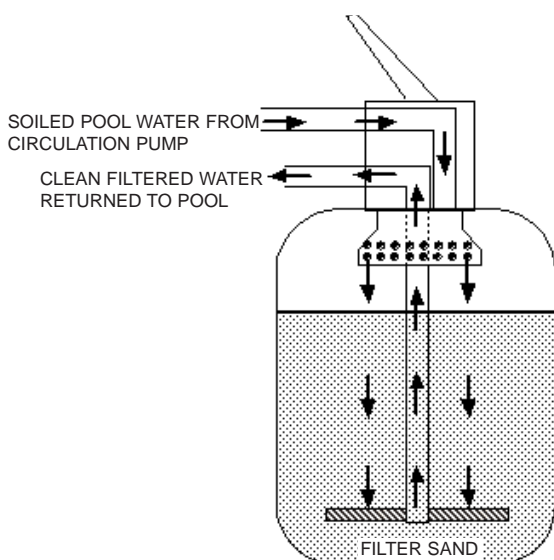

**dia.1 NORMAL FILTER CYCLE**

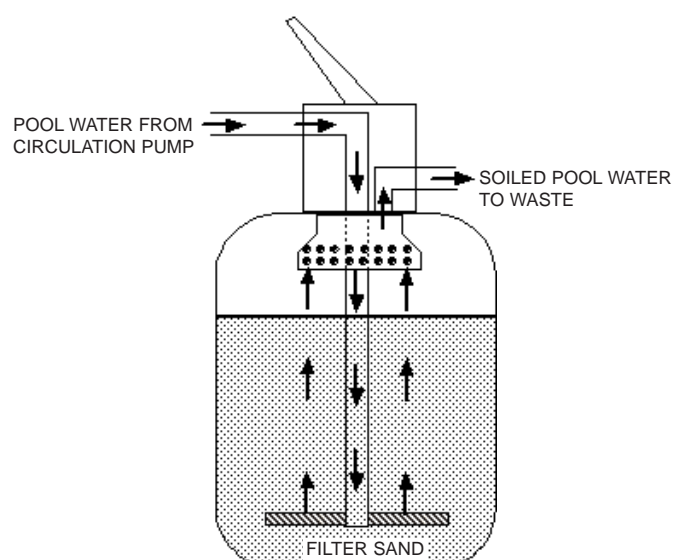

**dia.2 BACKWASH CYCLE**

## TO BACKWASH THE FILTER.

It is a good idea to top the pool up by a couple of inches, as you will be losing some to backwash/rinse.

*IF A 'ROLL-OUT' BACKWASH HOSE HAS BEEN SUPPLIED ENSURE IT IS ROLLED OUT!*

### NEVER MOVE THE MULTIPORT VALVE WHEN THE PUMP IS ON

- ◆ First switch heater off and allow to cool for 1 - 2 minutes.
- ◆ With the filter pump switched off-
- ◆ Depress the black multiport valve handle and turn to 'Backwash' position.
- ◆ Switch the filter pump on and allow to run for 3 minutes or until the water runs clear.
- ◆ Switch the pump off, depress the multiport valve handle and turn to 'Rinse' position.
- ◆ Switch the pump on and allow to run for 15 - 20 seconds.
- ◆ Switch the pump off, depress the multiport valve handle and return to 'Filter' position.

### CAUTION

Always ensure filter pump is switched off when moving the multiport valve handle. Always ensure filter pump is switched and valved off and return inlet is plugged before working on multiport valve.



## SIX POSITIONS OF A MULTIPORT VALVE (MPV)

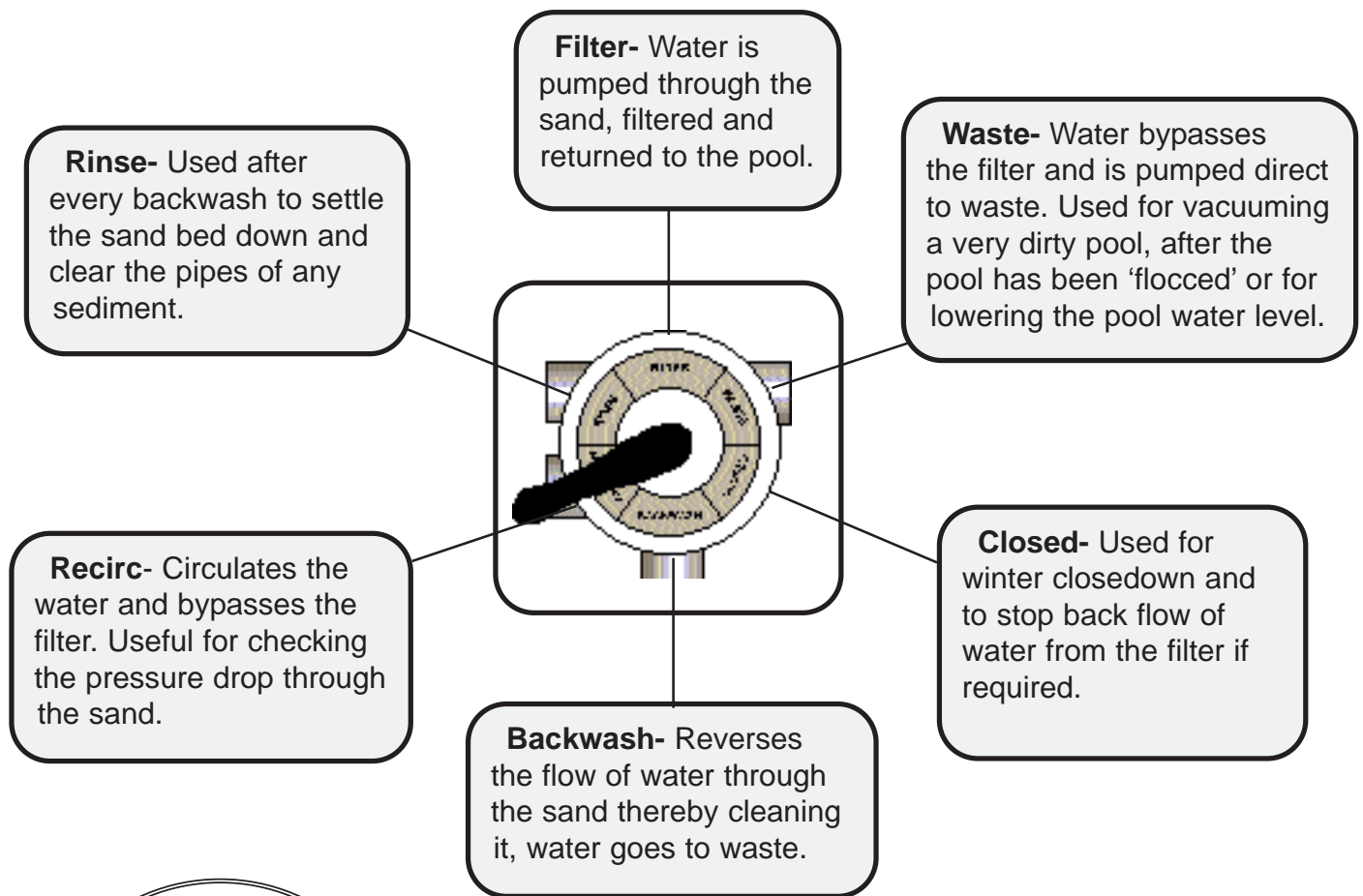

### REMEMBER!

Always backwash your filter at least once a week, regardless if it is clean or dirty. It will remove unnecessary chemical residue and maintain a healthy water balance.



## UNDERSTANDING YOUR POOL WATER.

**Filtered Water.** Your pool filtration system has been designed to circulate and filter the whole amount of water within the pool in approximately 8 hours. This is called 'the turnover period'. Ideally you should run the filter pump a minimum of 8 hours in every 24.

To achieve this turnover, fitted within the pool wall there is a surface skimmer and a return 'eyeball' inlet fitting.

You have a self-priming circulating pump, and a sand filter with multiport valve. Each piece of equipment is described in detail later.

The surface skimmer is plumbed with pipe work and a control valve to the circulating pump. This takes unfiltered water out of the pool and under pressure is forced through the sand filter to clean it of small particles, with clean filtered water being fed back to the pool via the 'eyeball' return fitting.

**Sanitised and pH Balanced Water.** It is vital to bathers health to maintain good wholesome water and to assist the efficiency of the filtration process. Pool water needs to be kept sanitised and pH balanced. This is to ensure it is kept free of algae, bacteria and bather pollution.

If left untreated pool water will quickly become algae infested (green), bacteria will build up causing possible infection and pollutants will make the whole pool very unpleasant.

Disinfection of pool water is carried out to rapidly destroy micro-organisms that may be harmful to bathers health. It is most important that a residual of sanitiser be maintained in the pool at all times. The most common form of pool sanitiser in use is stabilised chlorine granules or chlorine tablets (200grm Tri-Chlor Tabs).

The ideal level of chlorine residual to maintain is 1ppm to 2ppm. If the pool is to be heavily used this can be raised to 2ppm to 3ppm.

The other major consideration in pool water balance is the control of pH.

pH is an acid-alkaline scale, numbered from 0 to 14. Below 7 the water is acidic, above 7 and it is alkaline.

For pool water the ideal pH is between 7.2 and 7.6- if it is lower than 7.2 it will be too acidic and will seriously shorten the life of your equipment, especially heaters (if fitted) and the pump seal, in addition low pH can cause 'wrinkles' in PVC liners.

If the pH is above 7.6 it will be too alkaline, this will cause scale build up on pool liner and reduce the effectiveness of chlorine- either way this is not good for you, your pool equipment nor the efficiency of other control chemicals.

You will have been provided with and shown how to use the simple chlorine/pH & Alkavis test kit. Regular pool water testing and adjustment will ensure your pool is ready for use when you are!

Please test your pool water at least twice weekly.

With most domestic pool water test kits supplied (**See Fig.2 below**) there are two sample cells and three tests - one for pH, one for chlorine and one for Alkavis (to be dealt with later), the kit is supplied with foil wrapped DPD No1 (for chlorine), Phenol Red (for pH) and Alkavis (for total alkalinity) Testing Tablets.

### TO TEST YOUR POOL WATER -

At the pool side take stopper off of test sample cells, wash out the sample cells with pool water and fill to brim with pool water. Ideally always take sample from 18" below surface and from the same area of pool, away from the inlet.

Take one Phenol Red test tablet out of foil and place in pH cell, take one DPD No1 test tablet out of foil and place in Chlorine cell. Replace stopper and shake to dissolve. (Try not to touch the tablet as this will effect the result.)

The water sample will change to a colour of one of the sample colours (hopefully!)- try to match the your colour to a sample cell colour.

If the chlorine level is low put the filter pump onto continuous and add a chlorine booster tablet via the skimmer or shock dose, continue to run filter for 24 hours then re-test, if required add stabilised chlorine or a 200grm chlorine tablet to the skimmer. Return filter to normal pump position. Continue to test regularly.

If the pH reading is high add pH- (Dry Acid). If the pH is low add pH+ (Soda Ash). Generally pH tends to drift high.

(IF CHLORINE LEVEL IS HIGH- I.E. ABOVE 6ppm DON'T SWIM - TAKE CHLORINE TABLET OUT OF SKIMMER AND/OR WAIT!)

During the swim season it is worth Shock Dosing the pool after a party or after a thunderstorm, this is done with unstabilised chlorine such as Shock Chlorine (Calcium Hypochlorite) or Sodium Hypochlorite (Liquid Chlorine).

Should the pool start to go green the same applies, in addition, run the filter pump continuously for 2 - 3 days or until the water is milky to clear, you may need to add a Clarifier or Floc to the pool to get it clear- (Phone for advice).

### ,COVERS - SUMMER

To reduce water loss and therefore heat and chemical loss, it is wise to ensure the summer 'solar bubble' cover is fitted any time the pool is not being used. In addition you will enjoy the benefit of any solar gain. The solar cover is placed on the pool bubble side down!

When the solar cover is removed from the pool always store it in the shade and protect it with the white solar protector sheet to obtain maximum life from your solar cover.

## VACUUMING

To enjoy the most out of your pool you not only need to filter and chemically treat the water you also need to physically clean the pool of debris. A manual cleaning kit for this purpose consisting of a vacuum head, length of vacuum hose, telescopic pole. A leaf net and nylon brush are also available from your pool dealer.

The pool will need to be vacuumed on a regular basis.

### Vacuuming from the surface skimmer-

**option a/ For light debris-** plug the flooded vacuum hose directly into open hole found in bottom of skimmer.

**option b/ For heavy debris (i.e. leaves etc.)-** remove skimmer weir assembly, replace basket in skimmer and attach vacuum plate to top of skimmer basket, plug flooded vacuum hose into open hole found in middle of the vacuum plate as shown in diagram opposite.

Ensure skimmer valve is open, at pool side attach vacuum head to telescopic pole and vacuum hose to vacuum head.

Feed vacuum head, hose and pole into the pool near skimmer (keep hold of the vacuum pole to ensure you don't lose it in the pool!) Proceed with a or b described above.

If the pool is very dirty you may notice a loss of suction and it may be necessary to stop and clean the pump basket and/or backwash the filter and start again.

After vacuuming the pool-

At pool side take pole, hose and vacuum head out of pool and store. Replace skimmer basket, weir assembly and skimmer lid.

The filter pump basket may need cleaning and the filter may need backwashing after vacuuming.

You may find after 24 hrs that the pool floor is dirty again! This is due to very fine dirt particles passing through the filter. Re-vacuum the pool as described above or alternatively, try vacuuming the pool water to waste. See tip below.

**DO NOT TRY TO VACUUM A GREEN POOL (ALGAE) THROUGH THE FILTER - IT WILL PASS THROUGH THE FILTER BED! VACUUM TO WASTE.**

**Note - to remove debris from the pool filtration pump you will need to do the following:-**

**1. Insert a 1.5" threaded plug into the bottom of the skimmer prior to removing pump lid.**

**2. Turn Multiport valve to the 'closed' position.**

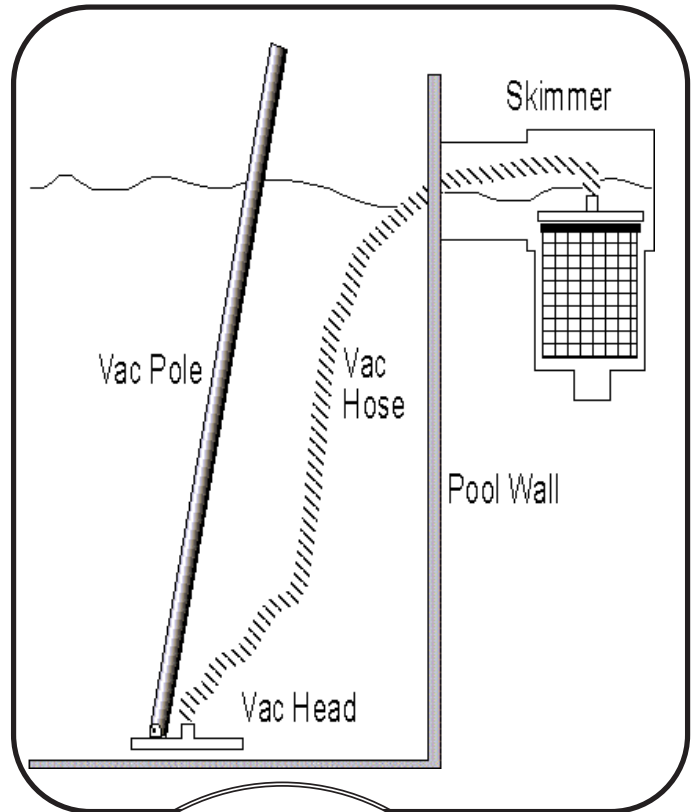

#### TIP!

If there is a heavy soil presence, try vacuuming the pool water to waste **using method a**. This will ensure that dirty water will not enter the filter. If using this method, make sure that you place a hose pipe into skimmer to replace water loss.

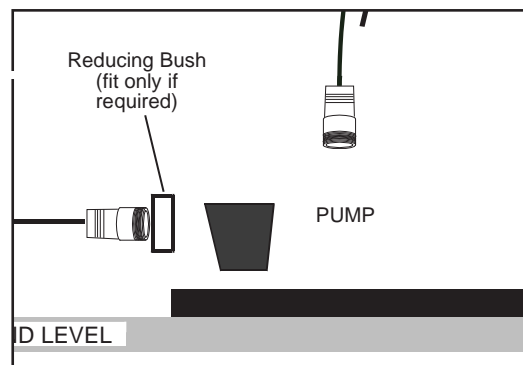

## POOL HEATING

Pool heating can be achieved using gas- natural and propane, oil, heat pump, heat exchanger- utilising your existing house boiler, electric or solar panels.

**Gas Heaters.** By far the most popular form, where natural gas is available, are direct fired natural gas heaters. These specifically designed and manufactured for swimming pools, they are practical, clean and efficient. Heaters are available for both indoor or outdoor 'flueless' installations, outdoor types are popular because there is no need for unsightly flue chimneys. A simple thermostat controls pool water heating.

Where propane gas heaters are installed invariably a gas tank has been sited and a contract has been made with a bulk supplier for regular top-ups of gas.

Be aware that whilst these heaters are suitable for outdoor installation all heater cases can be 'hot' and should have some barrier protection against contact with bare skin.

**Oil Heaters.** Invariably in country areas you will be using domestic fuel oil. Oil pool heaters can be 'direct', indoor or out conventional flued or 'indirect' pressurised sealed systems, again available either conventional or balanced flued.

Direct oil fired heaters are controlled by a simple thermostat. Indirect pressurised sealed systems have two thermostats, one controlling the primary hot water temperature and one for the pool water temperature.

**Heat Pumps.** These units are generally installed where there is no gas and oil is impractical due to distances from tank to heater. Heat pumps run off of electricity and basically operate like a fridge in reverse, they draw warm fresh air over a refrigeration system, the heat chilled from the fresh air, together with all the electrical energy consumed in operating the system is transferred via an integral heat exchanger to your pool water.

Heat pumps are considered to be super efficient and simple to install, however be aware that they will put heat into your pool water very slowly, typically it may take up to 2 weeks continuously running in the spring to achieve your desired temperature. Again in the autumn they may need to be run continuously depending on ambient temperatures.

**Heat Exchanger (Calorifier).** Where possible and practical a heat exchanger may be fitted to your existing house boiler and is simply another circuit i.e. a normal house system has one circuit for hot water and one for central heater, add a heat exchanger and you have a third.

Invariably your central heating programmer will have been changed and an additional primary hot water circulating pump will have been installed.

**Electric Heating.** Usually installed on smaller pools where there is no other source of heat or as heater 'boost' on pools with heat pumps or solar.

Electric heaters can be run on 'off-peak' with an over-ride if required and simple thermostat controls pool water heating. (Be aware that the time will need re-setting in the event of a power cut!)

**Solar Heating.** Solar heating panels are usually sited on a south or southwest facing roof or garden area near to the pool. Filtered pool water is diverted through these panels thus picking up any solar gain available.

Differential thermostats operating a motorised valve to ensure efficient running and to maximise solar gain control Solar heating.

When winterising your pool always remove the solar cover, clean it and allow it to dry. If left on the pool in icy conditions the cover life will be greatly reduced.

## SOLAR COVER ROLLERS (REEL ASSEMBLIES)

Although it is possible to cope with a solar cover by hand, it is a lot easier to remove and replace the cover with the aid of a solar cover roller.

## WINTER DEBRIS COVERS

A winter debris cover fitted to your pool will keep out the vast majority of leaves, twigs etc. whilst the pool is closed. Above ground winter covers are usually 1'-1'6" larger in each direction than the actual pool size and is held in place by means of a draw cord and ratchet.

The cover should lay on top of the pool water, once fitted run 1"-2" of water onto the top of the cover to keep it place, it is worthwhile to check for strap tension from time to time and adjust if required.

## DECOMMISSIONING YOUR POOL FOR WINTER

Whilst you can employ your pool supply company to carry out the winterisation to your pool it is quite possible with some basic skills to do it yourself.

Winterising your pool (putting it to bed) properly at the end of the summer season is very important, it will protect the equipment and done right will ensure the pool and equipment are good condition saving you time and money in the spring.

### To winterise your pool-

1. Remove the summer cover from the pool, whilst doing so hose off and brush the cover to ensure it is free of leaves and clean. If a roller is fitted, with the cover rolled up, cover it with the protector sheet and tie it up in several places. Raise one end of the roller and support it, this way any retained water will drain out, whilst this is happening you can proceed with the rest of the closedown.
2. With the filter multiport valve set to 'Waste' vacuum the pool clean, backwash the filter and follow up with a rinse, continue to lower the level of the pool water to approximately 6" below the skimmer mouth. This helps prevent frost/ice damage to the pool structure.
3. Remove ladders if fitted, clean and store.
4. Test pool water for pH and adjust if required. (Most winter algaecides work at their best with a pH of 7.2-7.4)
5. With the filter multiport valve set to filter (skimmer closed, main drain open) and pump switched on shock dose the pool with chlorine and add long life winter algaecide. Allow water to circulate for a period before switching pump off.
6. Check skimmer basket and clean. Do not leave any chlorine tablets in the basket. If the skimmer lid is broken, now is the time to replace it!
7. Fit winter cover ensuring straps are well tensioned. The cover should fit tight, it is worthwhile to check for strap tension from time to time through the winter and adjust if required.
8. Remove the roller assembly and store.
9. Switch off the power supply and turn off gas/oil valves.
10. In the plantroom ensure that the skimmer and main drain valve are open. Remove drain plugs from pump, filter and heater and lubricate with a water based grease. Remove pump lid and clean basket if required. It is a good idea to store all of the drain plugs in the pump basket, that way you will know where they are in the spring! With heat pumps ensure the water connections are undone to ensure all water escapes. With gas/oil heaters it is a good idea to replace the plugs loosely once the heater has drained (most heaters have a cast iron header and brass plugs, if left out over the winter you may find it difficult to fit the plugs).
11. As the winter progresses check the water level from time to time, with prolonged heavy rain and/or snow you may drain off more water. With the pool pump out of action you will need to do this either by siphon or submersible, if you don't own one most hire shops have them.

## COMMISSIONING YOUR POOL FOR SUMMER

Whilst you can employ us to carry out the spring commissioning to your pool it is quite possible with

### To commission your pool-

If need be- top your pool right up from a hose pipe (you will need this excess water for vacuuming to waste).

Remove the winter cover from the pool and spread out to dry.

Replace all of the drain plugs taken out of the filter, pump and heater (where fitted) when you closed the pool. (You should find them in the pump basket.)

Ensure that the skimmer valve is closed and the multiport valve is set to waste. Roll out backwash hose.

At poolside assemble the vacuum kit and plug hose in to skimmer outlet.

At the pump switch on and open skimmer valve and allow pump to prime.

Return to poolside and commence vacuuming the entire pool floor in a systematic pattern. (If leaves have entered the pool and collected vacuum these up last!) If vacuum seems to be poor check for a full pump basket or obstructions in the vacuum head.

After vacuuming the pool the water level should be at its normal running level, if it is low top it up from hose pipe again.

With the pool at the correct level return to plantroom and open skimmer valve. (Some air may enter system, this should clear in a few minutes.) At this point it is a good idea to give the filter a backwash, not forgetting to rinse! Leave filter running in filter position, if required switch the pool heating on (where fitted).

Return to poolside and remove the vacuum kit, net off any leaves etc.

Test pool water for pH and adjust if required. Shock dose pool to 10ppm and add long life summer algaecide.

Replace pool ladder, check ladder to ensure there are no missing or worn parts, if needed replace any parts before placing ladder in position otherwise damage may be caused to the pool liner.

Place roller/cover at end of pool, anchor roller if required and unroll cover onto pool.

Remove all debris from dried winter cover, fold/roll-up and store in summer storage bag.

# TROUBLE SHOOTING

## 1. Pool Pump-will not run-

check that power is on  
check that RCD (earth trip) & MCB is on  
check that time clock in 'timed' or 'on' position  
motor 'hums'-this indicates the pump impellor is jammed- phone for a service visit  
pump runs but no flow of water- see priming pump  
pump doesn't hold prime-see sand filter, air in filter

## 2. Sand Filter- no pressure on gauge-

check pump is primed  
check pump basket is free of debris  
check the pressure gauge needle has not jumped the needle post  
check suction valves are open

pressure gauge reading high-

give filter a good backwash and rinse  
check the pressure gauge needle has not jumped the needle post

air in the filter-

check pump lid 'O' ring and lid is in position and tight  
check all threaded connections in front of pump and ensure they are tight  
check water level in pool is not low and sucking air through skimmers

## 3. Heater- (Where fitted)

heaters (all) doesn't come on-

### IF IN DOUBT TURN OFF AND CALL FOR AN ENGINEER

check pool pump is on  
check there is a good flow of water, backwash and rinse filter  
run filter multiport valve in 'recirc' position- if heater then runs it is probably indicates a blockage in the sand- phone for an engineer  
most heaters have a delay timer, let filter pump run for 10 minutes  
check that the thermostat is calling for heat

gas heaters-

### IF YOU THINK YOU CAN SMELL GAS

don't turn electric switches on or off  
don't smoke  
don't use naked flames  
do turn off the gas supply at the meter  
do open doors and windows to get rid of the gas  
**CALL AT ANY TIME, TRANSCO-0800 111 999**  
check that gas valve is open  
if propane, is the tank full?, does the gas line need purging of air  
check that pilot light is on (where applicable)

oil heaters-

check that oil tank is full and valve open  
check the in-line oil filter is clean  
check the reset button on the oil burner

heat pumps-

if there is heat increase over a period of days and the unit constantly ices up or 'cycles'- call for an engineer  
check that air inlet grills are clean and pump is free of undergrowth!  
if heat pump under performs it may be low on gas- call for an engineer

heat exchangers-

check the 'domestic' boiler is on  
check that the boiler circulating pump is running  
check for air locks on both hot water and pool water circuits

## 4. Pool water-

air coming out of water inlet-

air is being sucked into system, check water level and the weir in skimmer basket, sometimes they get suck!  
Also see Pool pump- pump priming and Sand filter- air in filter  
Check Mech. Pump Seal

sand coming out of water inlets

is it sand or is it dead algae?  
if you can sweep it into a heap it's sand- call for a service engineer  
if it fluffs up into the water it's dead algae- vacuum to waste  
and ensure you backwash and rinse thoroughly

cloudy water-

water was clear and now cloudy?  
check pH and TA (Total Alkalinity), adjust as required  
shock dose with un-stabilised chlorine and leave filter to run continuously for 48 hours- you may need to floc as well!  
it was green, you shock dosed and it's now cloudy?  
floc the pool

wall and floor slippery-

check chemical level, shock dose, brush walls and floor  
leaving filter to run continuously for 48 hours- you may need to floc as well!